

SIDE VIEW

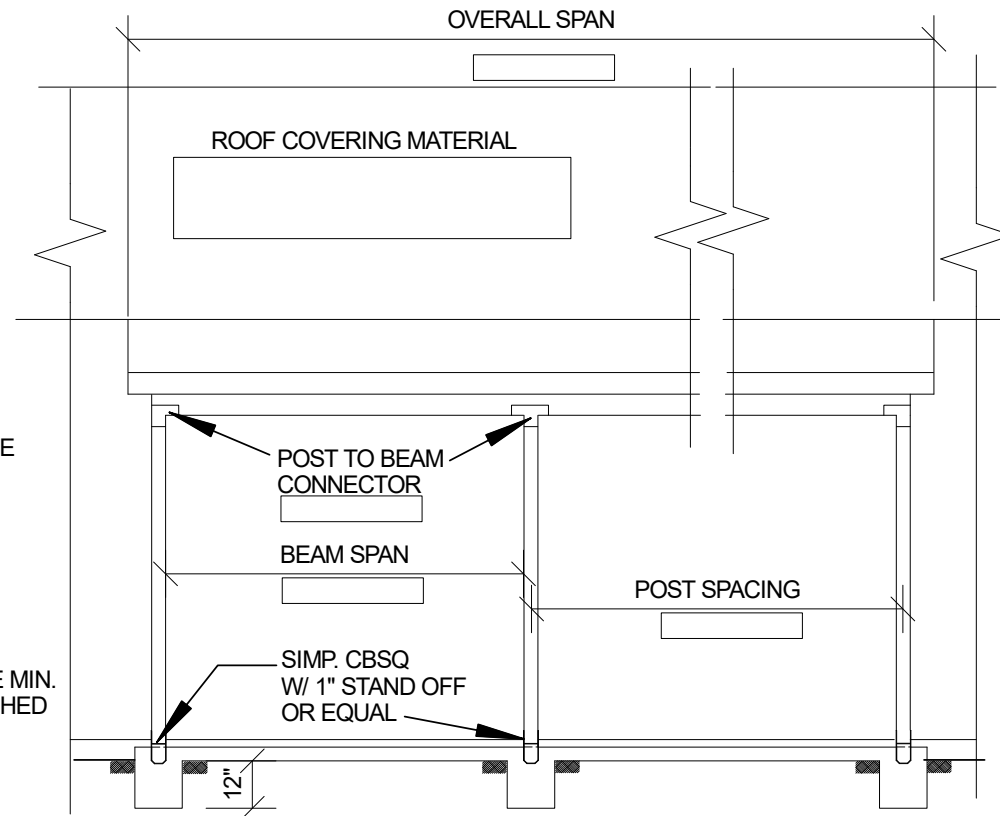

FRONT VIEW

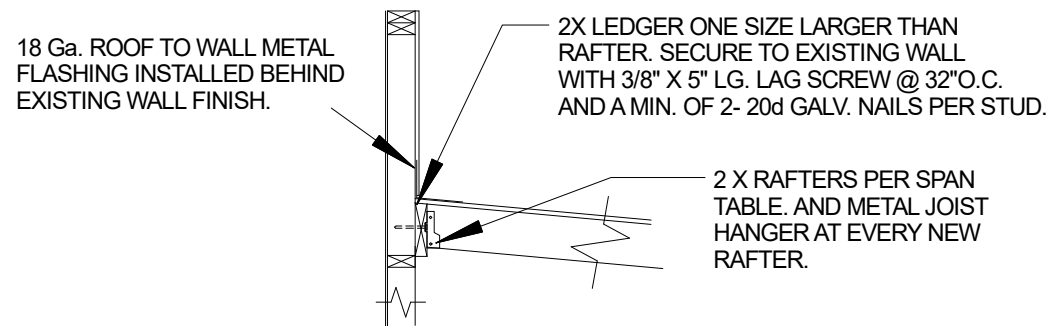

DETAIL "A"

NOTE:

1. NEW PATIO RAFTERS ATTACHED TO EXISTING HOUSE FACIA SHALL NOT EXCEED 10'-0" LONG. FACIA SHALL BE STRUCTURALLY SOUND AND SHALL NOT BE LONGER THAN 24" MAXIMUM.
2. TILE ROOF PATIOS ARE NOT ALLOWED TO ATTACH TO FACIA. PATIO STRUCTURE MUST BE ATTACHED TO HOUSE STRUCTURE.
3. COMPOSITION ROOF COVERING LIMITED TO A PITCH OF 2/12. 2 LAYERS OF 15# FELT IS REQUIRED.

INSTRUCTIONS

- a. FILL IN ALL PERTINENT BLANK BOXES.
- b. PROVIDE TWO COPIES OF DRAWINGS
- c. CIRCLE APPROPRIATE RAFTER SIZES AND SPANS

PATIO RAFTER SPAN TABLE FOR DOUGLAS FIR NO. 2 OR BETTER (ROOF LIVE LOAD 20 PSF, DEAD LOAD 20PSF)				
SIZE	SPACING	PLASTIC OR LATTICE	COMPOSITION/ ROLL	TILE
2X4	12"	9'-10"	9'-10"	0
	16"	8'-6"	8'-6"	0
	24"	6'-11"	6'-11"	0
2X6	12"	14'-4"	14'-4"	12'-4"
	16"	12'-5"	12'-5"	10'-8"
	24"	10'-2"	10'-2"	8'-8"
2X8	12"	18'-2"	18'-2"	15'-7"
	16"	15'-9"	15'-9"	13'-6"
	24"	12'-10"	12'-10"	11'-10"
2X10	12"	22'-3"	22'-3"	19'-1"
	16"	19'-3"	19'-3"	16'-6"
	24"	15'-8"	15'-8"	13'-6"

BEAMS SHALL BE DOUGLAS FIR #2 OR BETTER				
SIZE	SPACING	PLASTIC OR LATTICE	COMPOSITION/ ROLL	TILE
4X4	4'	4'	4'	4'
4X6	6'	6'	6'	5'
4X8	8'	8'	8'	7'
4X10	10'	10'	10'	9'
4X12	12'	12'	12'	11'
4X14	14'	14'	14'	ENGINEERING

BASED ON CRC, 2016 TABLE R802.5(1)

CITY OF LEMOORE
OPEN PATIO HANDOUT
(PATIO ATTACHED TO LEDGER)

PUBLIC WORKS
 BUILDING DIVISION
 711 CINNAMON DRIVE
 OFFICE # 559 924-6744 Ext. 730
 INSPECTION REQUEST 559 924-6744 Ext. 732
 REVISED 8-30-2015.
 MAY 11, 2016
 JULY 5, 2019

INSTRUCTIONS

- 1. DRAW A SITE PLAN WHICH INCLUDES THE FOLLOWING.
 - a. NORTH ARROW
 - b. SHOW LOCATION OF STREET AND STREET NAME.
 - c. FOOTPRINT OF HOUSE AND THE LOCATION OF PATIO.
 - d. SHOW DIMENSIONS OF PATIO TO ALL ADJACENT PROPERTY LINES.
 - e. INDICATE HOW STORM WATER WILL DRAIN AROUND PATIO.
 - f. PROVIDE 2 COPIES OF DRAWINGS .
 - g. PROJECT VALUATION \$ _____

OWNER INFORMATION:

NAME: _____
ADDRESS: _____
LEMOORE CA 93245
PHONE #: _____

CONTRACTOR INFORMATION:

NAME: _____
ADDRESS: _____
LIC. # _____
PHONE # _____

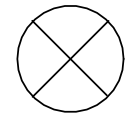

NORTH DIRECTION

CITY OF LEMOORE
SITE PLAN

BUILDING DEPARTMENT
711 CINNAMON DRIVE
LEMOORE CA, 93245
OFFICE # 559 924-6744 EXT. 730
INSPECTION REQUEST 559 924-6744 EXT. 732
REVISED 8-31-2015.
MAY 11, 2016, JULY 8, 2019